

CRIBUS

MOBILE ELECTRICAL DRUM SCREENS
WIDE RANGE OF APPLICATIONS
EFFICIENT HYDRAULIC DRIVE
MORE PERFORMANCE PER SCREEN AREA
DECIDEDLY ECONOMICAL





HIGHLIGHTS



- » Designed for economical operation
- » Energy, wear and maintenance costs minimized through innovative solutions
- » Electrical drive of all components for the highest energy efficiency
- » Available in three sizes to meet any performance need
- » Extensive options for individual configuration
- » User-friendly and reliable through new machine design



CRIBUS MORE UTILITY

The Cribus series redefines the term mobile drum screen. Numerous innovations create a machine with the highest level of functionality and cost-effectiveness, to set a new benchmark. The drive system is the basis for its extremely high cost-effectiveness - everything on the Cribus is driven electrically, from the hopper to the discharge belts.

This minimizes the energy, wear and servicing costs of the whole machine, backed up by the newly developed direct drum drive. The Cribus also offers compelling benefits in servicing and operational safety. Large flaps and doors, simple replacement of screen drum and conveyor belts, and well-designed safety mechanisms are hallmarks of the machine design.



01

Compost

Green compost, organic compost, sludge compost

Cribus drum screens demonstrate their talent for screening when used for composting. Controllable hopper and drum rotation speeds allow precise material alignment. Overfilling of the drum is prevented by load-dependent hopper control. The efficient cleaning brushes and uniquely generous clearance between drum and sidewalls prevent screen hole clogging, even with difficult materials. A standard screen drum or a drum with exchangeable screen segments can be used for screening, depending on requirements.



02

Wood/biomass

Shredded waste wood, woody biomass, wood chippings, bark

Komptech drum screens are also effective with high-bulk material. Steep hopper sides prevent bridging, and a wide conveyor with T-cleats feeds the material into the drum reliably. The large feed cross-section prevents material compression between hopper and screen drum so that the entire drum length is used to full advantage, for efficient screening. Extended discharge belts allow for high piles, and with a width of up to 1000 mm there are no blockages on the conveyor belt.



03

Soil/gravel

Excavated material, sand, gravel, light-weight building rubble

Heavy materials do not present problems for Cribus drum screens. Solid contraries are kept back by a hinged hopper pre-screen. A hopper belt controller prevents skewing of the belt. Automatic antislip control on the drive ensures that the drum turns even under extreme loading. Controllable belt speed and bolt-on cleats on the oversize fraction belt keep stones from rolling back.



04

Waste

Shredded bulky, household and residual waste, refuse derived fuels

Ample space between screen drum and sidewalls also makes operation with large screen hole sizes go smoothly. For these hole sizes, outside scrapers are more effective than circular brushes for drum cleaning. For residual waste screening, a special drum with anti-dirt strips is also available. Large side doors and flaps provide easy access for cleaning and servicing.



HIGHLIGHTS



- » The largest screening surface of any machine of its length
- » 20% more feed cross-section than the competition
- » New WHEELGRIP patented chainless drum drive
- » Easily handles a wide range of materials with hole sizes up to 100 mm
- » Drum with fixed hole size or flexible drum system with interchangeable screen segments, as desired



CRIBUS 2800

THE NEW BENCHMARK

With the largest screening surface for its overall length, the Cribus 2800 sets the standard in the compact class. Its large-diameter drum improves screening performance, and generous spacing between drum and sidewalls ensures trouble-free screening even for coarse sizes. This plus the easy operation and high economy of the Cribus 2800 make it perfect for a wide array of applications.

Contractors will appreciate the fact that due to the short length, a second drum can be transported by one truck. The use of interchangeable screening segments of highly wear resistant spring steel is particularly beneficial for multi-site use, as different mesh sizes can be transported with the screening machine (available for all types).



01

More performance per meter

Despite being only 10.6 meters long, the Cribus 2800 boasts a screening area of 28 m², made possible by the large 2.2 meter drum diameter. This makes material clumping between hopper and drum a thing of the past, so that the Cribus has a higher specific throughput (m³ per m² screening area) than competitors.



02

Broad range of applications

Steep sidewalls and a wide hopper belt prevent material bridging and enable screening of a broad spectrum of materials. The large drum diameter and generous clearance to the sidewalls allow smooth screening of fractions with larger shapes and sizes, even with the 100 mm screen hole size.



03

Efficient drum drive

The new maintenance-free friction wheel drive with the patented WHEELGRIP anti-slip technology gives maximum efficiency with minimum the costs for wear and servicing, since there are no chains, gears or additional bearings.

Details

Drive	
Electrical power input (kW):	25
Diesel generator (kVA):	30
Material feeding	
Hopper volume (m ³):	> 5,0
Screening drum	
Length (mm):	4600
Diameter (mm):	2200
Dimensions	
Transport dimensions L x W x H (mm):	10600 x 2550 x 4000
Throughput (dependent on material)	
Throughput performance (m ³ /h):	up to 170



04

Drum change in 5 minutes

Just fold down the sidewall for full drum access. To change the drum, the operator needs only run the hopper out of the drum, press a button to raise the drum, and then remove it with a fork loader or hoist. Experienced operators can do it in just a few minutes.

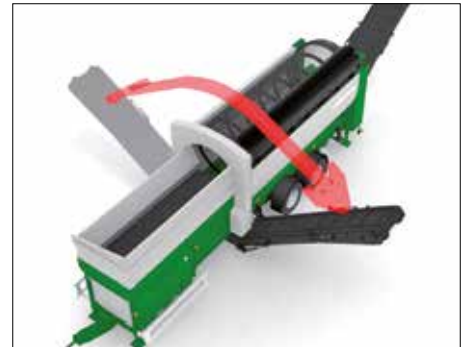

05

Right today, left tomorrow

The Cribus can be ordered with the fines discharge conveyor installed on either side, without affecting functioning. For users who want to stay flexible, an option is available that lets them switch the discharge side on-site. The corrugated belt conveyor gives high performance with low wear, and allows high material piles.

CRIBUS 3800

A step ahead through innovation.

A drum diameter of 2200 mm and an effective screen length of 5500 mm make the Cribus 3800 currently the largest mobile drum screen with central axle trailer. The large drum diameter and wide clearance to the sidewalls allow smooth screening of fractions with larger shapes and sizes, even with large screen hole sizes. The drum length gives good screening throughput and output quality.

To keep the Cribus series within statutory transport dimensions, the fine particle discharge belt is folded in next to the hopper for transportation, and moved out to the working position next to the drum with a patented movement mechanism.

A sturdy exterior shell, premium quality components, convenient operation, high operational safety and numerous options make the Cribus a valuable tool for tough daily usage.



Plenty of room in the hopper

- » Steep sidewalls prevent bridging
- » Automatic hopper belt controller for precise straight line travel
- » Hopper wall extensions can be fitted on right or left

01

Electrically adjustable round brush

02

Steep hopper walls with extensions that can be fitted on the right or left

03

Friction wheel drum drive with WHEELGRIP

04

Diesel generator hydraulically extendable

05

Discharge of fines with corrugated belt conveyor





Efficient drum drive

- » Maintenance-free drum drive with high-efficiency friction wheels
- » Even support wheel loading through all-wheel drive minimizes wear
- » WHEELGRIP anti-slip control prevents slippage



Low-wear discharge system

- » Collector conveyor moves against the material movement in the drum
- » Lower conveyor loading reduces wear and energy consumption
- » Corrugated side and fines discharge conveyor prevents leakage



Excellent maintenance access

- » Sidewall can be moved out hydraulically
- » Drum change is possible in a few minutes, without tools
- » Large panels and doors give ready access to all maintenance points



Clean drum

- » Electrically adjustable round brushes, with remote control if desired
- » Wide (140 mm) clearance between drive and sidewalls prevents clogs



Drive: Electric socket or generator

- » Ready for mains operation, with diesel generator option
- » Motor slides out hydraulically for maintenance (only for Cribus 3800)

Details

Drive	
Electrical power input (kW):	30
Diesel generator (kVA):	48
Material feeding	
Hopper volume (m ³):	> 5,0
Screening drum	
Length (mm):	6000
Diameter (mm):	2200
Dimensions	
Transport dimensions L x W x H (mm):	12000 x 2550 x 4000
Throughput (dependent on material)	
Throughput performance (m ³ /h):	up to 220



Nice to have

- » Hopper pre-screening, hopper sensor controller
- » Remote control, feed device
- » Central lubrication, Cleanfix fan and more



HIGHLIGHTS



- » The largest semitrailer-mobile drum screen
- » 7.7 meter drum length for excellent screening results, even with small hole sizes
- » Minimal energy, wear, and maintenance costs
- » High degree of maintainability with optimum accessibility and zero-maintenance solutions



CRIBUS 5000 GO BIG

The Cribus 5000 opens up a new dimension in drum screening. 50 square meters of screening area along a 7.7 meter long drum and a hopper holding over 6 cubic meters make it obvious who we designed this high-performance machine for - for users who want high throughput with great screening results, especially with small hole sizes.

For that, there is no substitute for drum length. But we did substitute the hydraulic drive - on this model, everything is electric. That minimizes energy, wear, and maintenance costs, and makes the big Cribus one of the most economical machines in its class.



01

Saving energy with hybrid technology

The power for the electrical drives comes directly from the mains or is generated by an integrated diesel generator.

Savings potential compared to diesel hydraulic drives:

In mains mode:

- » up to 75% lower energy consumption
- » up to 30% lower consumable parts costs
- » up to 25% lower operating costs
- » no servicing of the diesel unit or hydraulics unit

In generator mode:

- » up to 25% lower energy consumption
- » up to 15% lower consumable parts costs
- » up to 5% lower operating costs
- » no servicing of the hydraulic system



02

Little holes - big performance

With small hole sizes (< 20 mm) in particular, the length of the drum and its effective screening area become crucial factors. On its way through this 7.7 m drum, all the material is thoroughly screened, with performance that is unique on the market.



03

High degree of operator convenience

Thanks to its fully electronic control, this drive design features the highest ease of use. The display mode shows the operating status, and all functions are clearly visible and easily configurable. An automatic start-up and idling feature simplifies starting, and load-dependent hopper control prevents overloading of the screen drum.



04

Ready to go

Despite its impressive size, the Cribus is easy to manoeuvre as a semitrailer. Operation and maintenance are also simple and convenient. The operating panel with graphic control, automated starting and electric brush adjustment, plus options like hopper sensor control, remote control, hopper pre-screen and more, make this machine exceptionally operator-friendly.



05

Plenty of room in the hopper

The hopper is sized to match the high screening throughput. Its 6 m³ volume and 4.7 meter loading length make for easy loading with even large frontloaders. On the all-electric version without diesel auxiliary generator, the space saved results in a hopper volume over 8 m³.

Details

Drive	
Electrical power input (kW):	36
Diesel generator (kVA):	48
Material feeding	
Hopper volume (m ³):	> 6
Screening drum	
Length (mm):	7700
Diameter (mm):	2200
Dimensions	
Transport dimensions L x W x H (mm):	14000 x 2550 x 4000
Throughput (dependent on material)	
Throughput performance (m ³ /h):	up to 270



	Cribus 2800	Cribus 3800	Cribus 5000
Drive			
Electrical power input (kW)	25	30	36
Diesel generator (kVA):	30	48	48
Material feeding - feed hopper			
Hopper volume (m ³):	> 5.0	> 5.0	> 6.0
Filling length (mm):	> 4000	> 4000	> 4700
Filling width (mm):	1675	1675	1675
Filling height (mm):	2950	2950	2950
Screening drum			
Diameter (mm):	2200	2200	2200
Length (mm):	4600	6000	7700
Effective screening area (m ²):	28	38	50
Drum rpm:	max. 20	max. 20	max. 20
Material discharge (standard)			
Max. discharge height coarse fraction (mm):	2450 (Option 3500)	3500	3500
Max. discharge height fine fraction (mm):	2250 (Option 3350)	3350	3350
Dimensions			
Transport dimensions L x W x H (mm):	10600 x 2550 x 4000	12000 x 2550 x 4000	14000 x 2550 x 4000
Working dimensions L x W x H (mm):	13100 x 5000 x 4000 (Option: 14900 x 6560 x 4000)	16300 x 6560 x 4000	18350 x 6560 x 4000
Weight (t):	< 16.0	<18.0 (19.0)	<26.0
Throughput (dependent on material)			
Throughput performance (m ³ /h):	up to 170	up to 220	up to 270
Options			
Diesel generator, Cleanfix fan, magnet drum, adjustable belt speed, scraper for round brush, central lubrication, hopper pre-screening, hopper sensor control, remote control, feed device, attachment shoe, equipment according to EU directive and more			

CRIBUS 2800

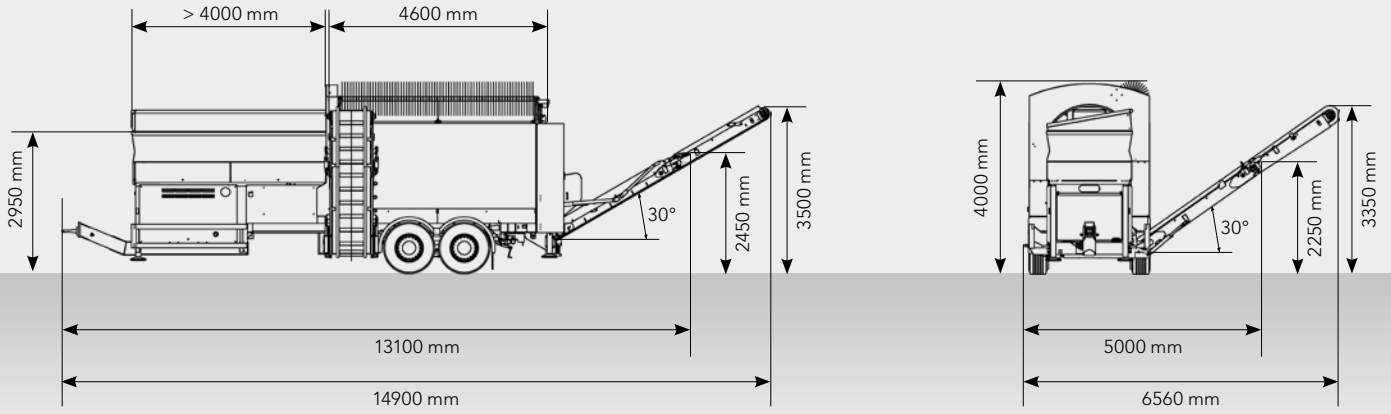

CRIBUS 3800

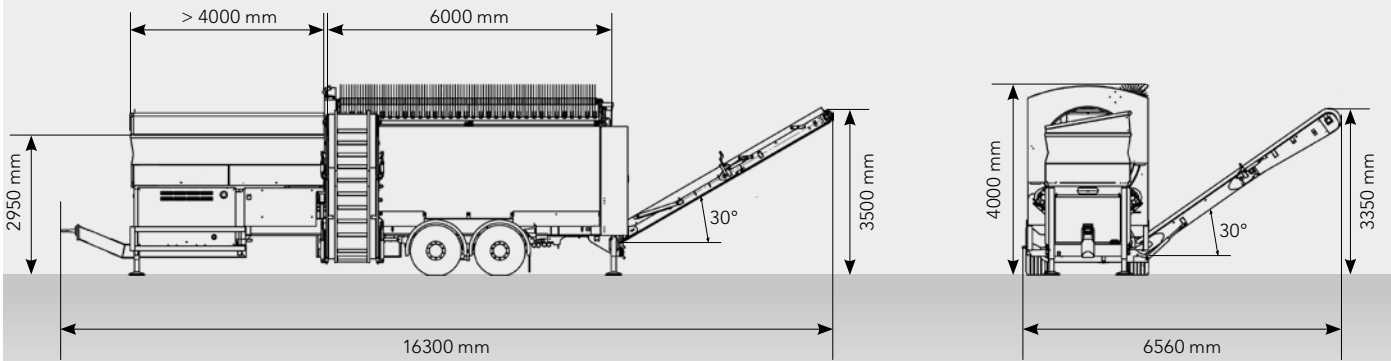

CRIBUS 5000

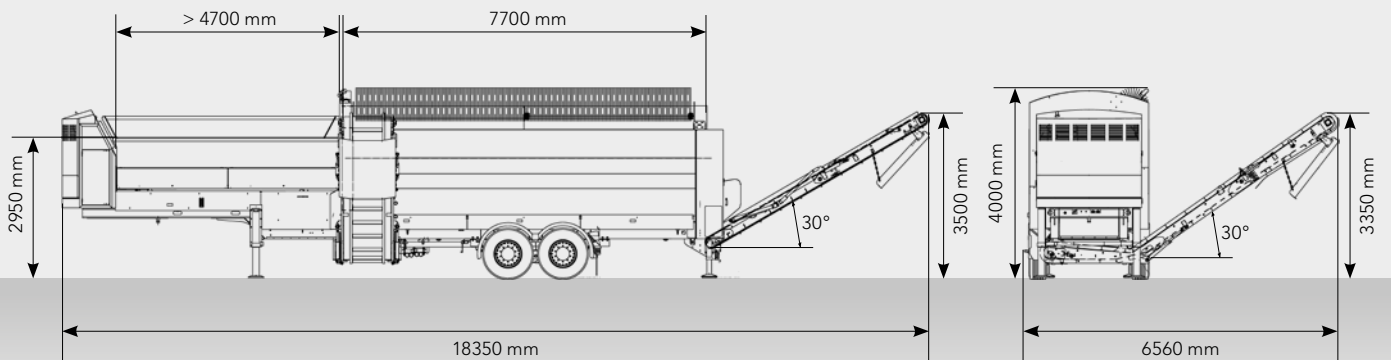

TECHNOLOGY FOR A BETTER **ENVIRONMENT**



Luke Ellens
DIRECTOR, SALES & SERVICE

Cel. 905 979 2640
Dir. 905 664 2080
l ellens@komptech.ca

1100 South Service Road
Suite 419, Stoney Creek,
Ontario, Canada L8E 0C5

komptech.ca
